

4 Holes 1/2"-13 UNC (0.015"Oversize)

x 0.59" deep on 3" PCD

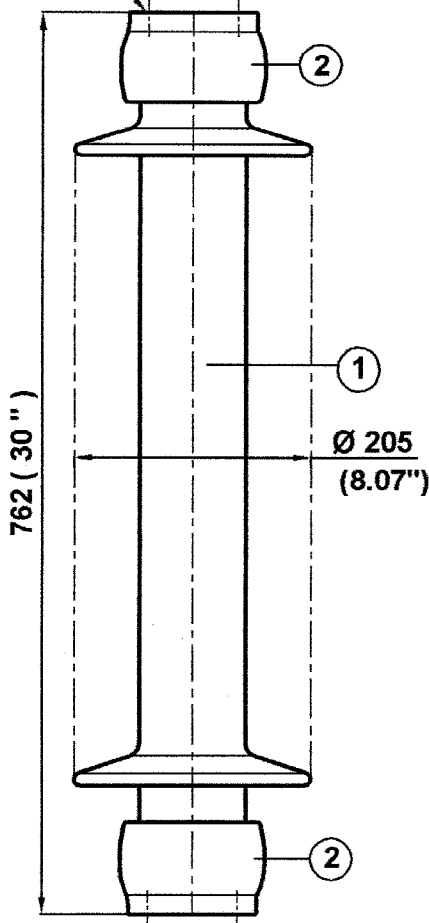

4 Holes 1/2"-13 UNC (0.015"Oversize)  
x 0.59" deep on 3" PCD

**TECHNICAL PARTICULARS**

**MECHANICAL VALUES**

Bending strength ( Upright & under hung )	lb	1500	kN	6.67
Compression strength	lb	25000	kN	111.2
Tensile strength	lb	16000	kN	71.2
Torsional strength	in lb	15000	kNm	1.69

**ELECTRICAL VALUES**

Dry power frequency withstand voltage	kV	165	
Wet power frequency withstand voltage	kV	145	
Dry power frequency flashover voltage	kV	210	
Wet power frequency flashover voltage	kV	190	
Lightning impulse withstand voltage	kVp	350	
Impulse flash over voltage	kVp	390	
Min. creepage distance	inch72	mm	1830
Shed profile as per IEC : 60815			

**RADIO INFLUENCE VOLTAGE DATA**

Test voltage to ground	kV	44
Max. RIV at 1000 kHz	µV	200

NOTE: -

Test & tolerance as per IS :2544 , 5350 & IEC :60168 ,  
273 & ANSI : C 29.9

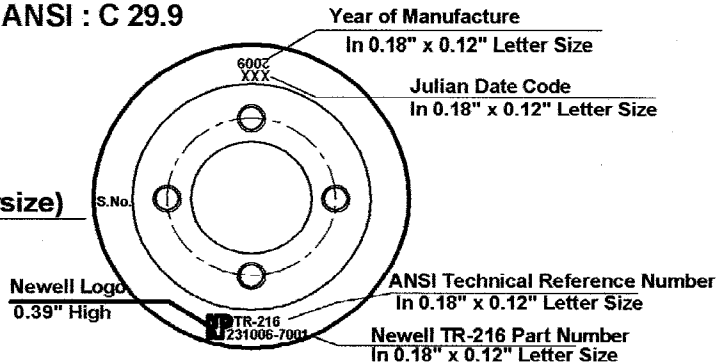

**Marking at top shed**

2	Caps	MCI / SGI	Hot dip galv .
1	Insulator body	Al. porcelain	Grey Glazed
S.No.	DESCRIPTION	MATERIAL	REMARKS

Title <b>STATION POST INSULATOR</b> ( BIL - 350 kV )		Scale N.T.S.	Matl. See table
Ref. TR : 216		Drawn	R.K.Malonia
		Checked	K.R.J.C.
		Approved	J.B.A.
All dimension are in mm/inch		Date	04 - 09 - 1993
<b>NEWELL PSN LLC</b>		Drg. No.	Rev.
		<b>212 - C - 092</b>	<b>5</b>

Rev. : - 5 On dated 23-11-1999