

4 Holes 5/8"-11UNC( 0.015"Oversize)

X0.866" deep on 5" PCD

**TECHNICAL PARTICULARS**

**MECHANICAL VALUES**

Bending strength ( Upright & Underhung )	lb	950	kN	4.22
Compression strength	lb	60000	kN	267
Tensile strength	lb	20000	kN	89
Torsional strength	in lb	40000	kNm	4.52

**ELECTRICAL VALUES**

Dry power frequency withstand voltage	kV	460	
Wet power frequency withstand voltage	kV	385	
Dry power frequency flashover voltage	kV	490	
Wet power frequency flashover voltage	kV	425	
Lightning impulse withstand voltage	kVp	900	
Impulse flash over voltage	kVp	1010	
Min. creepage distance	inch	165 mm	4191

Shed profile as per IEC : 60815

**RADIO INFLUENCE VOLTAGE DATA**

Test voltage to ground	kV	146
Max. RIV at 1000 kHz	µV	500

NOTE: -

Test & tolerance as per IS :2544 , 5350 & IEC :60168 ,  
273 & ANSI : C 29.9

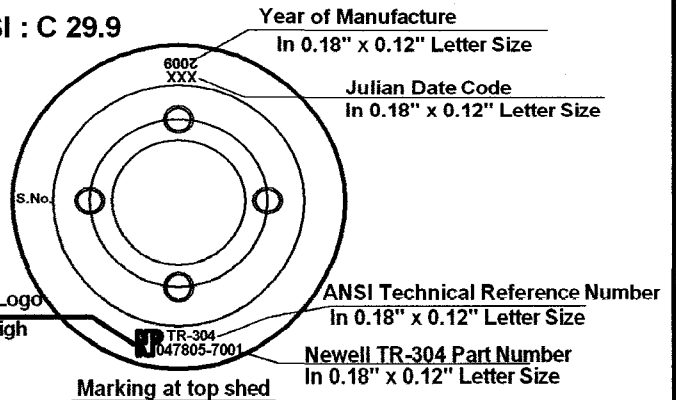
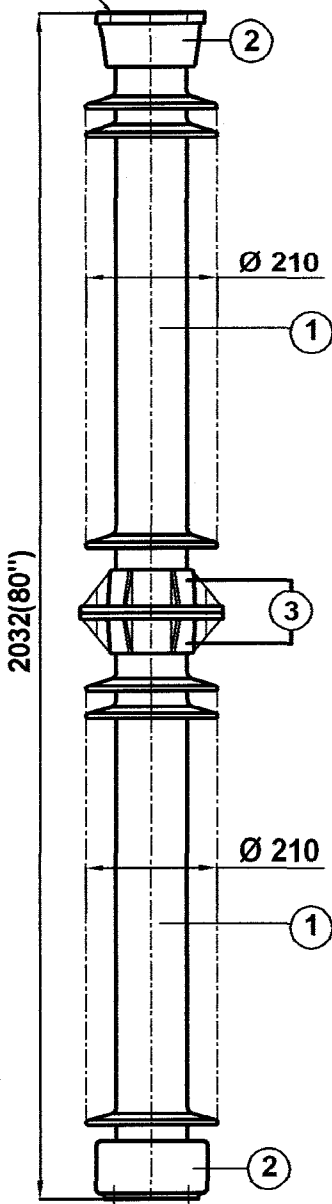

2 & 3	Caps & Flange	MCI / SGI	Hot dip galv .
1	Insulator body	Al. porcelain	Grey glazed
S.No.	DESCRIPTION	MATERIAL	REMARKS

Title <b>STATION POST INSULATOR</b> ( BIL - 900 kV )		Scale N.T.S.	Matl. See table
Ref. TR : 304		Drawn D.S.singh	Checked APN
All dimension are in mm.		Approved APN	Date 10-07-19991
<b>NEWELL PSN LLC</b>		Drg. No. <b>212 - C - 271</b>	Rev. <b>2</b>

Rev. : - 2 On dated 1-11-1999