

4 Holes 5/8"-11UNC( 0.015"Oversize)  
X0.866" deep on 5" PCD

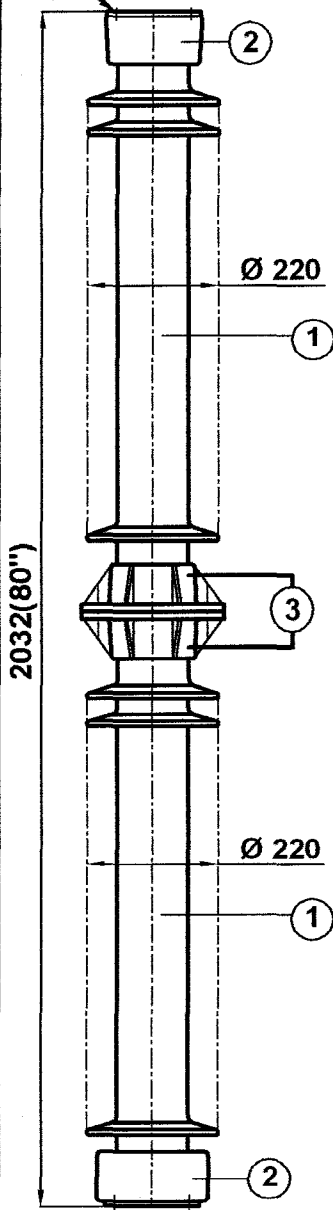

4 Holes 5/8"-11UNC( 0.015"Oversize)  
X0.866" deep on 5" PCD

## TECHNICAL PARTICULARS

### MECHANICAL VALUES

Bending strength ( Upright & Underhung )	Ib	1450	kN	6.45
Compression strength	Ib	90000	kN	400.32
Tensile strength	Ib	25000	kN	111.20
Torsional strength	in lb	90000	kNm	10.175

### ELECTRICAL VALUES

Dry power frequency withstand voltage	kV	460		
Wet power frequency withstand voltage	kV	385		
Dry power frequency flashover voltage	kV	490		
Wet power frequency flashover voltage	kV	425		
Lightning impulse withstand voltage	kVp	900		
Impulse flash over voltage	kVp	1010		
Min. nominal creepage distance	inch	165	mm	4195
Shed profile as per IEC : 60815				

### RADIO INFLUENCE VOLTAGE DATA

Test voltage to ground	kV	146
Max. RIV at 1000 kHz	µV	500

### NOTE: -

Test & tolerance as per IS :2544 , 5350 & IEC :60168 ,  
60273 & ANSI : C 29.9

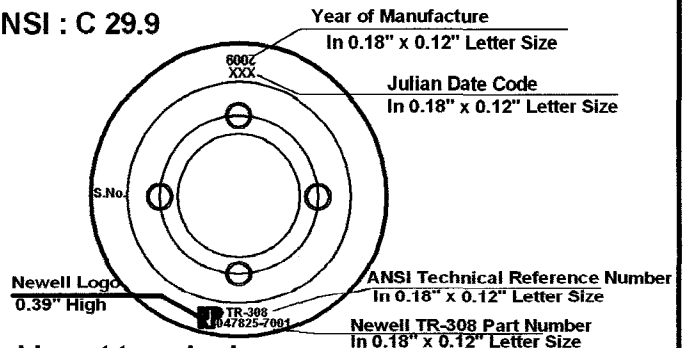

Marking at top shed

2 & 3	Caps & Flange	MCI / SGI	Hot dip galv .
1	Insulator body	Al. porcelain	Grey glazed
S.No.	DESCRIPTION	MATERIAL	REMARKS

Title <b>STATION POST INSULATOR</b> ( BIL - 900 kV )		Scale N.T.S.	Matl. See table
Ref. TR : 308		Drawn D.k.Gautam	Checked A.P.N.
All dimension are in mm.		Approved A.P.N.	Date 10 - 07 - 1991
<b>NEWELL PSN LLC</b>		Drg. No. <b>212- C - 323</b>	
		Rev. <b>2</b>	

Rev. : - 2 On dated 03-03-1999