

4 Holes 5/8"-11UNC (0.015"Oversize)
X 0.866" deep on 5" PCD

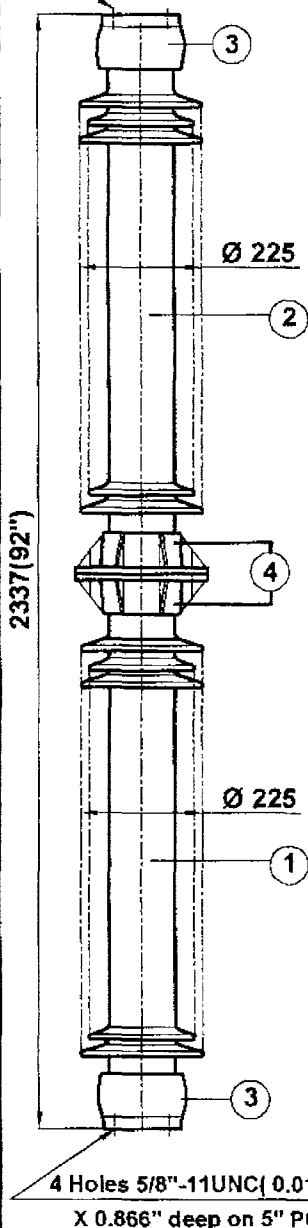

TECHNICAL PARTICULARS

MECHANICAL VALUES

Bending strength (Upright & Underhung)	lb	1250	kN	5.6
Compression strength	lb	90000	kN	400
Tensile strength	lb	25000	kN	111
Torsional strength	in lb	90000	kNm	10.2

ELECTRICAL VALUES

Dry power frequency withstand voltage	kV	515		
Wet power frequency withstand voltage	kV	455		
Dry power frequency flashover voltage	kV	545		
Wet power frequency flashover voltage	kV	485		
Lightning impulse withstand voltage	kVp	1050		
Impulse flash over voltage	kVp	1210		
Min. nominal creepage distance	inch	198	mm	5030
Shed profile as per IEC : 60815				

RADIO INFLUENCE VOLTAGE DATA

Test voltage to ground	kV	146
Max. RIV at 1000 kHz	µV	500

NOTE: -

Test & tolerance as per IS :2544 , 5350 & IEC :60168 ,
273 & ANSI : C 29.9

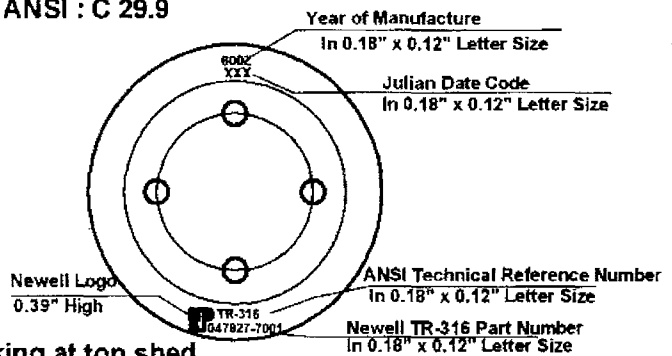

Marking at top shed

3 & 4	Caps & Flange	MCI / SGI	Hot dip galv .
1 & 2	Insulator body	Al. porcelain	Grey glazed
S.No.	DESCRIPTION	MATERIAL	REMARKS

Title STATION POST INSULATOR (BIL - 1050 kV)		Scale N.T.S.	Matl. See table
Ref. TR : 316		Drawn R.K.Malonia	Checked KR JC
All dimension are in mm.		Approved JBA	Date 07-10-1994
NEWELL PSN LLC		Drg. No. 212- C - 258	Rev. 3